



European Open meeting held under the National Sporting Code and Standing Regulations for Road Racing of the ACU

2011 MANX GRAND PRIX REGULATIONS

CONTENTS

1	ANNOUNCEMENT	Page 2
2	SECRETARY OF MEETING	Page 2
3	OFFICIALS	Page 2
4	COURSE	Page 2
5	RACE PROGRAMME	Page 3
6	ELIGIBILITY	Page 3
7	ENTRIES AND ENTRY FEES	Page 6
8	INSURANCE AND MACHINES ON PUBLIC HIGHWAY	Page 6
9	SIGNING-ON / BRIEFING	Page 7
10	TECHNICAL INSPECTIONS	Page 8
11	FLAG SIGNALS	Page 11
12	PRACTICES	Page 11
13	QUALIFICATION	Page 13
14	CHANGE OF NUMBER	Page 13
15	RACE PROCEDURE	Page 14
16	PROTESTS AND APPEALS	Page 16
17	WINNERS ENCLOSURE	Page 16
18	GARLANDING CEREMONY	Page 17
19	AWARDS	Page 17
20	TRANSPONDERS AND AUTOMATIC TIMING	Page 19
21	ON BOARD CAMERAS AND GLOBAL POSITIONING SYSTEMS	Page 19
22	MOBILE PHONES	Page 19
23	PADDOCK	Page 20
24	PERSONNEL PASSES	Page 22
25	VEHICLE RECOVERY SERVICE	Page 23
26	ACCEPTANCE OF RECORDS	Page 23
27	BREACH OF REGULATIONS	Page 23
28	INDEMNIFICATION OF THE CLUB	Page 23
29	JURISDICTION	Page 23
30	PUBLICITY	Page 23
31	MERCHANDISING	Page 24
32	MISCELLANEOUS	Page 24
33	USEFUL CONTACTS	Page 25
	APPENDIX I Technical requirements for all machines	Page 26 - 27
	APPENDIX ii Eligibility for Classic race machines	Page 28 - 29
	SUMMARY OF TIMES	Page 30 - 31

IMPORTANT NOTICE

INSURANCE

NO MOTORCYCLE may be ridden on open roads, not even to and from the starting point at any time, without Road Traffic Act Insurance. This cover may be obtained from the Race Office.

Riders may wish to explore the possibilities of arranging cover through their own insurers for this purpose.

Third party insurance for all riders and personal accident insurance for ACU and SACU licence holders during the races and official practices are included in the Entrance Fee. Non ACU and SACU licence holders must have Personal Accident insurance as required by their own national federation (see Reg. 8).

Insurance for increased benefits can be effected by application direct to Motor Sports Risk Services, Lockton Companies International Ltd., Hanover House, 30/32 Charlotte Street, Manchester, M1 4FD (tel: 0161-228-0721) or during signing-on periods at the Race Office, Grandstand, Douglas, Isle of Man.

SPECIAL POINTS

- (1) Entries close on the Saturday 11 June 2011 in accordance with Regulation 7.
- (2) All Competitors resident in the UK must have held as a minimum a National Licence issued by the ACU or SACU for at least six months prior to the first day of practising. Competitors from other Federations within the UEM must have held as a minimum a National Licence for a minimum of six months prior to the first day of practising (Reg 6).

In addition to enter this event all competitors must hold a "TT Course Licence" issued by the ACU at a cost of £25.00 in addition to any normal licence fees. An application form for such a licence is enclosed and should be returned to the Auto Cycle Union. Please note - A "TT Course Licence" issued by the ACU does not guarantee an entry into the Manx Grand Prix Races.

- (3) Competition licences, starting permission (for non ACU/SACU licence holders) and TT Course licences detailed in Reg 6 (a)(1) must be produced when signing on (Reg 9)
- (4) Riders with previous experience on the TT Course may apply for dispensation to the Clerk of the Course to commence practice no later than Wednesday 24 August. All newcomer riders in the Classic or Newcomers Races must have commenced practice on Saturday 20 August and completed 3 laps before Wednesday 24 August (See Reg 13).
- (5) Riders may use their own painted backgrounds but if they do so they must be matt and the RAL colours specified (See Reg 10).

MMCC Office,
The Grandstand,
Glencrutchery Road,
Douglas,
Isle of Man,
IM2 6DA.

Telephone : (01624) 644649
Fax : (01624) 620174
E-mail: mgp@manx.net
www.manxgrandprix.org



I. ANNOUNCEMENT

Manx Motor Cycle Club Limited, "MMCC" (a company incorporated in the Isle of Man (no 007491C)) whose registered office is situated at The Grandstand, Glencrutchery Road, Douglas, Isle of Man, IM2 6AD, ("the Club") will organise the Manx Grand Prix Races over the TT Mountain Course in the Isle of Man from 27 August to 2 September. Official Practice will be from 20 to 26 August with additional practice on 27, 29 and 31 August. Permit No ACU 31467 and Temporary Course Certificate No TT001. UEM Inscription No. EMN 10/263.

The MMCC is the owner of the logos, associated trademarks and designs of the Manx Grand Prix races and has agreed to grant to DTL the use of same for the term of the existing contract between the parties. The Department of Economic Development "DED" (an Isle of Man Government Department), whose registered office is St Andrews House, Finch Road, Douglas, Isle of Man, IM1 2PX, is the owner of the logos, associated trademarks and designs of the Manx Grand Prix Festival.

The status of the Meeting is European Open. The Meeting will be held under the National Sporting Code and Standing Regulations for Road Racing of the ACU, these supplementary regulations and any further instructions issued or official announcements made. ("The Regulations".) The Club may publish supplementary instructions on the official notice board in the Race Office at the rear of the Grandstand. Riders will be deemed to have received due notice of any instruction so published.

The regulations will not be altered, except as provided for in the National Sporting Code and may be interpreted only by the Stewards of the Meeting. Their decisions will be final except as provided in the National Sporting Code.

2. SECRETARY OF THE MEETING

Caroline Etherington,
MMCC Office,
The Grandstand,
Glencrutchery Road,
Douglas,
Isle of Man,
IM2 6DA.

Telephone : (01624) 644649
Fax : (01624) 620174
E-mail: mgp@manx.net
www.manxgrandprix.org

3. OFFICIALS

ACU Steward:	TBA
ACU Centre Steward:	Edric Costain
Club Steward	Martin Blackburn
ACU Delegate	Eddie Nelson
Clerk of the Course:	Philip Taubman ACU 29276
Deputy Clerk of the Course/Operations:	Andrew Mackay
Deputy Clerk of the Course/Start/Finish:	Peter Cain
Chief Incident Officer:	Ned Bowers
Chief Medical Officer:	Dr Heike Romer
Chief Timekeeper:	Kevin Brookes
Chief Technical Officer:	Jeff Kirby
Deputy Chief Technical Officers:	Peter Maddocks/Joanne Rowe/Trevor Denning
ACU Sound Inspectors:	Mike Chapman/Sharon Hibberd
Engine Measurer:	Keith Spencer/Joanne Rowe/Trevor Denning
Riders Liaison Officers:	John Barton/Carolynn Sells

4. COURSE

The Meeting will be held on the 'Mountain' circuit which is 60.70km (37.73 miles) in length, on highway which is closed to the public during practice and race periods.

5. PROGRAMME OF RACES

Saturday 27 August

1730 Race 1 The NEWCOMERS RACE 3 laps) in 2 capacity classes run concurrently

Monday 29 August

1015 Race 2 The 350cc/250cc CLASSIC GRAND PRIX RACE (4 laps) in 2 capacity classes run concurrently

1315 Race 3 The JUNIOR MANX GRAND PRIX RACE (4 laps)

Wednesday 31 August

1015 Race 4 The 500cc CLASSIC GRAND PRIX/FORMULA CLASSICRACE (4 laps) in 2 capacity classes run concurrently

1315 Race 5 The SUPERTWIN/LIGHTWEIGHT MANX GRAND PRIX RACE (4 laps) in 2 capacity classes run concurrently

Friday 2 September

1015 Race 6 The SENIOR MANX GRAND PRIX RACE (4 laps)

1315 Race 7 The CLASSIC SUPERBIKE/JUNIOR POST CLASSIC RACE (4 laps) in 2 capacity classes run concurrently

6. ELIGIBILITY

(a) Riders Licences

- (1) ACU and SACU licence holders must have held as a minimum a National Licence issued by the ACU or the SACU for at least six months prior to the first day of practising. Competitors from other Federations within the UEM must have held as a minimum a National Licence issued by their FMN for a minimum of six months prior to the first day of practising.

In addition to enter this event all competitors must hold a "TT Course Licence" issued by the ACU at a cost of £25.00 in addition to any normal licence fees. An application form for such a licence is enclosed with these Supplementary Regulations.

(2) Eligibility

In these regulations and in any other instructions or directive issued by the Club, the term "rider" shall refer to any person who has been accepted as a rider in any of the races.

Riders must be 18 years or older on 20 August 2011.

(3) Additional conditions for classes

Newcomers

The only riders eligible for the Newcomers Race and the only riders regarded as newcomers in the Classic Races shall be those who have not previously qualified to ride or ridden in any motorcycle race run over the TT Mountain Course. A rider who has previously competed on the TT Mountain Course only as a TT sidecar driver or passenger is regarded as a Newcomer in the Manx Grand Prix. Riders entering the Newcomers Race may also enter for the Junior, Lightweight, Super Twin or Senior races but may compete in these races only if they have qualified to start in the Newcomers Race and achieved the qualifying time for the other races entered.

Classic Superbike, Junior Post Classic & Classic Races

There are no additional conditions.

Super Twin, Lightweight, Junior & Senior Manx Grand Prix

- (i) Previous winners of Newcomers, Classic, Post Classic, Lightweight, Ultra Lightweight, Junior and Senior Manx Grand Prix Races will be considered (subject to (ii) below).
- (ii) Riders who have previously competed in any TT solo race on the TT Mountain Course (except Production or Historic TT Races) are NOT eligible if:-
- they have qualified to start in any TT solo race on the TT Mountain Course in the last two years, eg a rider who wishes to compete in the 2011 Manx Grand Prix must not have qualified to start in any TT solo race on the TT Mountain Course in 2010 and 2011.
 - they have won a silver replica in any TT solo race on the TT Mountain Course in the last four years, eg a rider who wishes to compete in the 2011 Manx Grand Prix must not have won a silver replica in any TT solo race on the TT Mountain Course from 2008-2011 inclusive.

Note – Should a rider be in doubt as to the status of any event he/she may have entered he/she should contact the Secretary of the Meeting.

(4) General

- (a) **Change of Rider:** Only with the permission of the Clerk of the Course may a change of rider be allowed. Such permission will be granted only in exceptional cases and after investigation. A substitute rider may be nominated only by a licensed entrant. A change of both rider and make of motorcycle may be permitted at the discretion of the Clerk of the Course.
- (b) **Medical Examinations:** The Club may require any rider at his/her expense to undergo a medical examination by a doctor or by the medical board appointed by the Club and may disqualify a rider on medical advice. Every rider agrees to the results of any such medical examination being given to the Club.

A rider involved in an accident will not be allowed to continue practising or racing until he/she has been passed medically fit by one of the event Medical Officers.

- (c) **Entrants:** Entrants must be in possession of a current National or International entrants licence for road race.
- (d) **Machines:** Solo machines are eligible to compete in the races as follows:

Race 1 NEWCOMERS RACE in 2 capacity classes run concurrently ie

Class A

550cc – 750cc	4 stroke 4 cylinder
651cc – 1000cc	4 stroke 2 cylinder
601cc – 675cc	4 stroke 3 cylinder
601cc – 1000cc	rotary equivalent
201cc – 450cc	2 stroke 2 cylinder

Class B

Up to 125 cc	2 stroke single cylinder; 6 gears maximum
251cc – 400cc	4 stroke 4 cylinder; Rebores up to Manufacturer's maximum rebores sizes are permitted
Up to 450cc	4 stroke single cylinder
Up to 650cc	4 stroke 2 cylinder

Race 2 - 350cc/250cc CLASSIC GRAND PRIX RACE in 2 capacity classes run concurrently ie

Class A - 350cc Classic

300cc - 350cc

Class B - 250cc Classic

175cc - 250cc

Race 3 JUNIOR MANX GRAND PRIX RACE

201cc – 250cc	2 stroke 2 cylinder
550cc – 600cc	4 stroke 4 cylinder
601cc – 675cc	4 stroke 3 cylinder
651cc – 750cc	4 stroke 2 cylinder

Race 4 500cc CLASSIC GRAND PRIX/FORMULA CLASSIC RACE in 2 capacity classes run concurrently

Class A - 500cc Classic

301cc–500cc

Class B - Formula Classic Race

501cc – 850cc, 4 stroke.	Cut off date 31st December 1974.
450cc – 600cc, 2 stroke.	Cut off 31st December 1969.

Race 5 SUPER TWIN/LIGHTWEIGHT MANX GRAND PRIX RACE in 2 capacity classes run concurrently ie

Class A - SuperTwin

201cc – 350cc 2 stroke 2 cylinder
Up to 650cc 4 stroke 2 cylinder

Class B - Lightweight

Up to 125 cc 2 stroke single cylinder; 6 gears maximum
251cc – 400cc 4 stroke 4 cylinder; Rebore up to Manufacturer's maximum rebore sizes are permitted
Up to 450cc 4 stroke single cylinder

Race 6 SENIOR MANX GRAND PRIX RACE

550cc – 750cc 2/4 stroke 4 cylinder
651cc – 1000cc 4 stroke 2 cylinder
601cc – 675cc 4 stroke 3 cylinder
601cc – 1000cc rotary equivalent

Race 7 CLASSIC SUPERBIKE/JUNIOR POST CLASSIC RACE in 2 capacity classes run concurrently ie

Class A - Classic Superbike

601 - 1050cc 4 stroke and 351 - 750cc 2 stroke, cut off date 31st December 1985.

Class B - Junior Post Classic

Up to 600cc 4 stroke, cut off date 31st December 1985.

126-250cc Grand Prix Factory Bikes Steel frame or period aluminium frame, any brakes, any wheels, cut off date 31st December 1984.

126-250cc. Standard frames, Standard fairing. Any ignition. Any brakes. Any wheels. No airboxes. Maximum 4 transfer ports for Yamaha barrels.

Cut off dates 1st January 1985 - 31st December 1991.

251-350cc Steel frame, any brakes, any wheels. Cut off date 31st December 1985.

Note: 'cut off' means that machines were manufactured and available for purchase in Europe before the date stated.

The general eligibility is that machines are to be manufactured before 31st December 1985, or manufactured in subsequent years without substantial alteration. Machines may also incorporate components of a type manufactured before 31st December 1985, or manufactured after that date without substantial alteration. Riders are encouraged to present machines with visible components (eg wheels) of a type available in the period.

In particular, and with reference to each machine:

- Wheels must be of a size available as at 31st December 1985
- The maximum allowed tyre width will be: front 120 and rear 180
- Suspension systems: must be of a type available as at 31st December 1985 (subject to the replacement of shock absorbers)
- Forks: must be of a type available as at 31st December 1985
- Engines: must be of a type available as at 31st December 1985
- Engines with more than two valves per cylinder are restricted to their original capacity
- Engines must be complete and as originally produced by the manufacturer
- Carburettors: must be of a type available as at 31st December 1985
- Frames and swinging arms: must be of a type available as at 31st December 1985 except for two strokes within the Junior Post Classic
- For Classic Superbike and up to 600 cc four strokes running in the Junior Post Classic, brakes must be of a type available as at 31st December 1985.

If, in the opinion of the Committee, sufficient entries are not received for any class, the Club may at its discretion amalgamate that class with any other class, and/or offer entrants the opportunity to transfer to another class and change their machines to one eligible for the other class.

ALL MACHINES MUST COMPLY WITH APPENDIX I AND ADDITIONALLY ALL CLASSIC MACHINES MUST COMPLY WITH APPENDIX II.

7. ENTRIES AND ENTRY FEES

- (a) All entries must be made on the official entry form and sent to the Secretary of the Meeting by Saturday 11 June with the appropriate entry fees, see below:- See Reg 8 for non ACU & SACU Licence Holders.

	ACU / SACU	Non ACU / SACU
<i>All classes except below:</i>	£315 per race	£220 per race
<i>Classic 250/350/500cc, Formula Classic, Classic Superbike, Junior Post Classic:</i>	1 Race - £315 2 Race - £473 2 Race - £630	1 Race - £220 2 Race - £330 2 Race - £440

- An administration fee of £25 will be payable for entries received after Friday 29 April after 5.00 pm.. Modern and Classic Newcomers will be exempt from this surcharge.
- Credit/debit cards and cheques will be accepted. Cheques to be made payable to Manx Motor Cycle Club Limited.
- The Club reserves the right to refuse any entry and abandon, cancel or postpone the meeting or alter the programme of events and awards.
- Unless, in the opinion of the Club, sufficient entries are received for a race, that race will not be held, in which case entry fees will be returned.
- The entry fee may be returned in full if an entry is refused, but there is no other right to a refund and any given will be at the discretion of the organisers.
- A maximum of 90 starters will be permitted for each race starting singly at 10 second intervals. If more than 90 entry applications are received for any race:
 - (i) priority will be given to Manx Grand Prix Replica winners in the last two years.
 - (ii) the remaining entries up to 90 will be allotted at the Club's discretion.
- Reserve Entries: For each race reserve entries may be accepted in addition to the maximum of 90 confirmed entries. Subject to qualification they will take places (if available) but not necessarily the starting numbers of confirmed starters up to a maximum of 90 starters per race. New numbers will be allocated at the discretion of the organisers to reserves when they are guaranteed a start.
- Riders may apply for entries in more than one race (subject to eligibility under Reg. 6).
- Riders (except all Newcomers) may apply to enter two races run on the same day provided they do not use the same machine.

8. INSURANCE/MACHINES RIDDEN ON PUBLIC HIGHWAY

(a) Insurance

The Organisers undertake to insure each rider, indemnifying him/her against any third party claims made arising out of the races or official practice, excluding claims by other riders, entrants, sponsors or mechanics.

Competitors who hold licences issued by the ACU or the SACU will be covered by Personal Accident insurance during official practice and racing, for the benefits detailed below. The cost of this Personal Accident insurance is included in the entry fee. Competitors holding licences issued by a FMN other than the ACU or SACU must submit a Starting Permission countersigned and stamped by the FMN which issued their licence. This must confirm that, during the meeting and the official practice, they are insured against the risk of personal accident in accordance with the FIM Sporting Code but with additional cover for Medical Treatment and Repatriation costs, as follows:-

- 25,000 Euros - Death
- 50,000 Euros - Temporary Partial Disablement
- 185,000 Euros - Medical Treatment
- 75,000 Euros – Repatriation costs

Alternatively this cover may be purchased from the event Insurance Brokers in the Race Office at the Grandstand during signing on periods. The entry fee for these riders will be £220 as the cost of their personal accident insurance will not be paid by the Club.

For ACU and SACU licence holders, the organisers will arrange personal accident cover for the following benefits:

- £10,000 GBP Death or permanent total disablement
- £20,000 GBP Loss of, or loss of the use of, one or more limbs or eyes

Increased insurance benefits can be arranged either in the Race Office at the Grandstand (during the MGP fortnight) or by application to:

Motor Sport Risk Services, Lockton International, 19 Spring Gardens, Manchester, M2 1FB

Tel: +44 (0) 161 828 3300, Fax: +44 (0) 161 828 3335, E-mail: dawn.luby@uk.lockton.com, www.locktonmotorsports.com

During the whole of the time the competing motorcycles are in the custody of the Club the motorcycles will be insured by the Club against damage by fire up to a maximum value of £25,000 per machine

(b) Machines on the Public Highway

The law of the Isle of Man provides that racing machines shall not be ridden on the public highway, except being used on a journey:-

- (i) between the place where it is kept and the start of the Course
- (ii) between the place where it is kept and a point on the Course
- (iii) from a point on the Course to the place where it is kept; or
- (iv) between points on the Course

The above is applicable for a period of 3 hours before and 2 hours after a closure period provided that the motorcycle in question is competing in a practice or race during the closure period. During these times, third party insurance must be effective, for the person riding the machine. Any rider reported as having driven his/her motorcycle in such a manner as to constitute a nuisance to the public or in contravention of any law or statutory regulation may be disqualified or otherwise penalised. Third party insurance cover can be obtained from the Race Office. Machines used on the public roads outside these times must comply in every respect with Manx road traffic laws and race numbers must not be displayed.

9. SIGNING-ON/BRIEFING

(a) Signing-on

All riders must sign-on at the Press Office, The Grandstand between the following times:

<i>Friday 19 August</i>	<i>1300 – 1600 (All riders including Newcomers)</i>
<i>Saturday 20 August</i>	<i>0900 – 0930 (Newcomers only followed by course instruction)</i>
	<i>0930 – 1100 (All other riders)</i>

- Competition licences, starting permission (for non ACU/SACU licence holders) and TT Course licences detailed in Reg 6 (a)(1), plus leathers, helmets (with visor), boots, gloves, transponders and identification disc MUST be produced personally for examination.
- Local addresses and telephone numbers must be supplied. Any notices posted in the Race Office or sent by the Club to riders at such addresses shall be deemed to have been served.
- All Race Office opening times will be displayed outside the Race Office.
- A declaration must be signed by riders, confirming that they have not sustained any injury or consulted with a doctor regarding any injury or illness since the issue of their licences.
- Each Newcomer will be required to wear a red waistcoat at all times during practice sessions. Non Newcomer Classic riders will be required to wear white waistcoats when practising. Waistcoats will be supplied by the Club during signing-on sessions. Replacements can be purchased at a cost of £10 each.

(b) Newcomers' Course Instruction

- All Newcomers (irrespective of class) will be taken around the course by coach/minibuses on SATURDAY 20 AUGUST at 0930 hrs with an experienced instructor/s. This is compulsory and failure to attend may result in disqualification. All Newcomers (irrespective of class) to attend the Newcomers briefing upon their return to the Grandstand.

(c) Riders Briefings

- All riders must attend a briefing prior to being permitted to commence practice. The briefings will take place in the Conference Suite adjacent to the Race Office at the following times:

<i>Friday 19 August</i>	<i>1400</i>	<i>1500</i>	<i>1630</i>
<i>Saturday 20 August</i>	<i>1115 (All riders except Newcomers)</i>	<i>1200 (Newcomers Only)</i>	
<i>Monday 22 August</i>	<i>1600</i>		

- All Newcomers must arrive, sign on, and take the Newcomers Course Instruction at 0930 hrs and attend the Newcomers briefing at 1200 hrs on Saturday 21 August or they may be disqualified.

(d) Technical Briefings

- A technical briefing for competitors and one mechanic per competitor will be held on Saturday 20 August, in the Conference Suite adjacent to the Race Office at the following times:-

<i>All riders except Classic</i>	<i>1315</i>	<i>Classic riders</i>	<i>1400</i>
----------------------------------	-------------	-----------------------	-------------

- It is important that each rider is represented at this briefing.

(e) Newcomers' Pre-Race Briefing

- A pre-race briefing will be held on SAT 27 AUGUST at 1100 in the Pit Lane area if dry and Technical Inspections Bay if wet. This is compulsory.

10. TECHNICAL INSPECTIONS

(a) Number plates

Self-adhesive numbers and backgrounds must be supplied by the riders. Numbers must be legible and any numbers not meeting with the approval of the Chief Technical Official must be replaced. However riders may use painted backgrounds but if they do so they must be matt and the following colours must be used following the RAL colour table:-

Black	9005
Blue	5010
Yellow	1003
Red	3020
White	9010
Green	6002
Orange	2007

Three numbers, placed and fixed as directed by the Club shall be displayed on the motorcycle during practice periods and races so as to be clearly visible to marshals from the front and both sides of the machine.

The colours for practice and race number plates will be as follows:

Newcomers	Red plates with White digits
Classic Superbike/Junior Post Classic	Orange plates with Black digits
Classic 350/250cc	White plates with Black digits
Classic 500cc/Formula Classic	Black plates with White digits
Junior	Blue plates with White digits
Lightweight/SuperTwin	Green plates with White digits
Senior	Yellow plates with Black digits

Please also note:

Any rider entered in more than one race on the same machine using the same engine will practice on one colour plate only

- Junior and SuperTwin - practice on Junior plates (blue) - see example below in bold
- Senior and Junior - practice on Junior plates (blue)
- All Newcomers will practice on red plates throughout, except those in 2 or more classes on different machines
- Formula Classic & Classic Superbike/Junior Post Classic – practice on Formula Classic plates (black)

A rider who is entered in SuperTwin & Junior on a 250 cc machine who has only one machine must practice on Junior plates (blue). However if he/she proves to the Chief Technical Officer that he/she actually has two identical 250 cc machines, he/she will also use SuperTwin plates (green).

(b) Pre Practice Technical Inspections

All machines bearing the correct number plates must pass through the Technical Inspections Bay for inspection/approval prior to practice, during the times listed. All riders must similarly pass through the Technical Inspections Bay with leathers, helmets, boots, gloves and identification discs prior to any practice. All helmets must have the official Technical Officers' sticker attached. Technical Inspections commence at the following times:-

Saturday 20 Aug	1500-1600 1530-1910 1630-2010	Newcomers incl Classic, C/Superbike & Jun P/Classic Newcomers Senior, Junior, SuperTwin (No Newcomers) Classic, C/Superbike, Jun P/Classic, Lightweight
Monday 22 Aug	1600-1900 1715-2000	Senior, Junior, SuperTwin (No Newcomers) Classic, C/Superbike, Jun P/Classic, Lightweight, Newcomers A & B
Tuesday 23 Aug	1600-1900 1715-2000	Classic, C/Superbike, Jun P/Classic, Lightweight, Newcomers B Senior, Junior, SuperTwin, Newcomers A
Wednesday 24 Aug	1600-1900 1715-2000	Senior, Junior, SuperTwin, Newcomers A Classic, C/Superbike, Jun P/Classic, Lightweight, Newcomers B

continued overleaf

Thursday 25 Aug	1600-1900 1715-2000	Senior; Junior; SuperTwin, Newcomers A Classic, C/Superbike, Jun P/Classic, Lightweight, Newcomers B
Friday 26 Aug	1600-1900 1715-2000	Classic, C/Superbike, Jun P/Classic, Lightweight, Newcomers B Senior; Junior; SuperTwin, Newcomers A
Saturday 27 Aug*	1600-1900 1715-2000	Senior; Junior; SuperTwin, (No Newcomers) Classic, C/Superbike, Jun P/Classic, Lightweight (No Newcomers A & B)
Monday 29 Aug*	1000-1130	All Classes except Newcomers A & B, Junior; 350/250cc Classic
Wed 31 Aug*	1000-1130	Senior; Classic Superbike, Jun Post Classic

* subject to race delays

(c) **Pre-Race Technical Inspections**

Motorcycles must be presented for pre-race Technical Inspections at the Technical Inspections Bay on each race day for all riders racing on that day at the following times, which must be strictly adhered to.

Newcomers Sat 27 August

All Nos	1500-1630
---------	-----------

All Other Classes

Nos 61 upwards	0800-0830
Nos 31 – 60	0830-0900
Nos 1 – 30	0900-0930

Any application for extension must be made during the times stated above

- NB - Riders need not necessarily present their motorcycles personally but must report personally wearing their protective clothing, helmets, visors, boots, gloves and identification discs not less than one hour before the scheduled start time of the race. Non-compliance with this regulation renders the riders liable to disqualification.
- All competing motorcycles must be presented with stands and in all respects ready for the race. The Chief Technical Officer or his Deputy may exceptionally grant extensions to ensure that a machine is properly prepared.
- Motorcycles must, therefore, be presented for Technical Inspections, ready in all respects, for the start of the race, including fuel. The motorcycles will remain in the custody of the Club, after presentation, until 45 minutes before the start.
- Riders and attendants shall leave the holding area immediately after their motorcycles have been placed there after Technical Inspections and should note that except by leave of the Club's Technical Officers they cannot have access to their machines after the pre-race Technical Inspections until 45 minutes before the start.
- No one other than riders, pit attendants and the officials can be admitted to the Technical Inspections Area and holding area.

(d) **Post Race Examination**

- Every competing motorcycle must be placed in the finishing enclosure where it will be held for as long as may be required. Motorcycles must be collected immediately following an official announcement that they have been released, after which the Club disclaims any responsibility for motorcycles not collected. No responsibility is accepted for equipment at any time.
- Motorcycles may be examined at the end of the race by the Club's Technical Officers and may be sealed by the Club's Technical Officers for later examination. Every rider shall dismantle, or cause to be dismantled at his/her own expense such parts of his motorcycle as the Clerk of the Course may require for the purposes of such examination, at such time and place as the Chief Technical Officer shall require.
- No rider shall be deemed to have finished a race or to have set up or broken a lap record or to have accomplished the fastest lap in a race until his/her motor-cycle has been examined if so required, and passed.

(e) **General**

- Helmets and visors, leathers, boots, gloves, identification discs and motorcycles must be produced personally by each rider for re-examination if a rider falls off his/her machine or at any time if required by the Chief Technical Officer. Riders shall remove fairings from their machines if required by the Chief Technical Officer.

(f) Change of Motorcycle

An entrant wishing to change the make or type of motorcycle, after entries have closed, must apply to the Race Office for approval by the Clerk of the Course, not later than 24 hours before the scheduled start time of the race. The rider must have qualified on the -class of the machine to be raced. The rider must have completed 1 practice lap on the machine to be raced. No change of class will be permitted after Tuesday 23 August. NOTE: For the purpose of these regulations, make of machine will be determined by the make of the engine and the make of the engine must be declared at the time of registration.

(g) Fuel

Fuel for all practices and races must be one of the following and comply with the general specifications listed in Table 1. Furthermore, only the specified fuel type is permitted for use in classes or engine types as given in Table 2.

Table 1. Fuel type general specifications.

Property	Max Lead Mg/l	MAX RON	MAX MON	Oxygen% m/m	Benzene% v/v
Unleaded petrol	5	102	90	2.7	1.0
Leaded petrol	150	102	90	2.7	1.0
Avgas 100 LL	560	-	102	2.7	5.0

Values in this table are taken from the FIM/ACU regulations and are applied to the fuel types as indicated. For a full specification refer to the FIM regulations for fuel. Alternatives to Avgas 100LL are NOT permitted.

Table 2. Motorcycle classes and engine types with permitted fuel for use.

	Classics – all classes inc. 2 stroke Classics	Any other 2 stroke	Up to 1000cc 4 strokes other than Classics
Unleaded petrol	YES	YES	YES
Leaded petrol	YES	YES	NO
Avgas 100LL	YES	YES	NO

Where a competitor is using other than Isle of Man sourced pump fuel he/she MUST provide a specification sheet for that fuel when requested by the Chief Technical Officer.

These regulations strictly prohibit the use of 'Bluegas', power boosters, octane boosters and the like. No additions are allowed to the fuel with the exception of water or standard lubricants sold to the public. The responsibility for providing fuel for practice and races will be the competitor's.

It is also the competitor's responsibility to ensure that his allocated filler, which will be provided, operates correctly. Any fuel left in fillers will be drained and removed, however it is the competitor's responsibility to check that his filler has been drained prior to adding his own fuel. The use of other quick-filling equipment will not be allowed.

The Steam Packet Company has stated that fuel may only be carried in the tanks of machines, cans/barrels will not be allowed. Spot checks will be carried out and anyone found in contravention of this ruling will not be permitted passage to the Island.

In the practice or races, no fuel shall be carried on the motorcycle other than in the tank securely fitted to the motorcycle for the purpose.

The Club reserves the right at any time before, during or immediately after practising or racing to take samples of the fuels used.

During practice periods riders can only refuel in the holding area to the north side of the Technical Inspection Bays, engines must be stopped.

Competitors must supply information at signing on regarding the quantity and location of fuel stored outside the Grandstand. This information will be supplied to the Isle of Man Fire Service.

(h) Fuel Tanks/Capacities

In the interest of safety, the use of ready fuelled replacement tanks in the pit WILL NOT be permitted.

Replacement tanks are permitted but must be empty and may only be filled when securely attached to the machine. Refuelling during the progress of any race must be carried out at the competitors designated pit. It is forbidden to open tank filler caps until the machine is stationary at its allotted pit and the engine is switched off. Penalty may be disqualification.

The maximum permitted tank size is 24 litres.

The use of temporary filling material to reduce the capacity of the tank is forbidden.

11. FLAG SIGNALS.

*The following flag signals may be used during practice or a race, and must be **immediately obeyed**.*

NATIONAL FLAG - start

RED (waved) - immediate stop, all riders. Pull in where safe. Await marshals' directions.

BLACK WITH ORANGE DISC - with rider's number - that rider to stop immediately due to mechanical problems.

YELLOW (motionless) - danger ahead, slow down, no overtaking.

YELLOW (waved) - danger more imminent- slow down - be prepared to stop - no overtaking.

CHEQUERED - individual finish

The following advisory flag signals may be displayed:-

YELLOW AND RED STRIPED - lack of adhesion

WHITE WITH BLACK "V" - bad visibility warning.

WHITE WITH BLACK "SUN" or "S" - sun dazzle.

WHITE - there is a slow moving intervention vehicle on the track. Riders may not overtake other riders but may overtake the intervention vehicle.

GREEN - course clear.

12. PRACTICE

(a) General

Practice on the Course, which will be closed to the public, will be regulated and supervised by the Club and will be allowed ONLY from the 20 August at the times specified. The practice schedule may be altered by the Clerk of the Course due to circumstances or force majeure.

During any practice period, the Clerk of the Course or his deputy may decide to flag off riders between Governor's Bridge and the finishing line, in which case the foreshortened lap and the time recorded at the flagging off point will be counted towards qualification for the races.

The end of each practice session will be notified by the showing of yellow, chequered and red flags, as detailed at the riders briefing.

All riders will slow down and leave the course as directed, where a red flag is shown.

Fire retardant overalls must be worn by all mechanics/assistants in the warm-up area. Footwear worn by attendants must adequately protect the foot and not contain any studs, steel tips or anything likely to cause a spark.

(b) Practice Periods

Saturday 20 Aug	1720-1745 1745-1855 1900-2010	Newcomers including Classic, C/Superbike & Jun Post Classic, Newcomers (speed controlled) (untimed) Senior, Junior, SuperTwin (No Newcomers) (untimed) Classic, C/Superbike, Jun P/Classic, Lightweight, All Newcomers (untimed)
Monday 22 Aug	1820-1900 1905-2000	Senior, Junior, SuperTwin (No Newcomers) Classic, C/Superbike, Jun P/Classic, Lightweight, Newcomers A & B
Tuesday 23 Aug	1820-1900 1905-2000	Classic, C/Superbike, Jun P/Classic, Lightweight, Newcomers B Senior, Junior, SuperTwin, Newcomers A
Wednesday 24 Aug	1820-1900 1905-2000	Senior, Junior, SuperTwin, Newcomers A Classic, C/Superbike, Jun P/Classic, Lightweight, Newcomers B
Thursday 25 Aug	1820-1900 1905-2000	Senior, Junior, SuperTwin, Newcomers A Classic, C/Superbike, Jun P/Classic, Lightweight, Newcomers B
Friday 26 Aug	1820-1900 1905-2000	Classic, C/Superbike, Jun P/Classic, Lightweight, Newcomers B Senior, Junior, SuperTwin, Newcomers A
Saturday 27 Aug*	1910-1920 1930-1940	Senior, Junior, SuperTwin (No Newcomers) Classic, Classic Superbike, Junior Post Classic, Lightweight (No Newcomers A & B)
Monday 29 Aug*	1515-1620	All Classes except Newcomers A & B, Junior, 350/250cc Classic
Wed 31 Aug*	1515-1525	Senior, Classic Superbike, Junior Post Classic

The above times are subject to alteration due to circumstances or force majeure.

Please note:

Motorcycles raced in the Junior race may not be used in the Monday 29 August practice session. Applications to practice out of session will not be considered unless in exceptional circumstances.

13. QUALIFICATION

To start a race, a newcomer to the TT Course, qualifying for the first time must complete a total of at least 6 laps, including a speed controlled lap. Newcomers in any class must have signed on, attended the Newcomers briefing and the Course Instruction on Saturday 20 August and commenced practice, including completion of a speed controlled lap and must have completed 3 laps on or before Wednesday 24 August, or they may be disqualified.

1. Riders who have qualified to start in any previous race on the Mountain Circuit (TT or MGP) shall be required to have signed on and commenced practice on or before Wednesday 24 August to complete a total of at least 5 laps.
2. A minimum of 2 laps (3 laps in the case of newcomers) must be completed on each machine entered, one of which must be within the qualifying time.

In every case all qualifying laps must be completed on the motorcycle to be ridden in the race or on a machine of the class.

Qualification times

Newcomers A & B, Senior, Junior, SuperTwin, Lightweight: *115% of the time set by the third fastest qualifier in the class*

Classic Races including Classic Superbike/Junior Post Classic: *120% of the time set by the third fastest qualifier in the class*

Unless otherwise decided by the Clerk of the Course the qualifying times will be based on the times set at the close of practice on Friday 26 August. All qualifying, including that on race days will be officially timed and count towards qualification. Qualifying must be at the sole discretion of the Clerk of the Course and there will be no right of Protest or Appeal.

A rider, who is entered in more than one race on the same machine, may achieve a qualifying time during a race in order to compete in a subsequent race.

14. CHANGE OF NUMBER

No applications for a change of number will be accepted. This means no rider will be permitted to fill in the 'Application to the Clerk of the Course' form requesting a change of number. The Clerk of the Course does however reserve the right to make a change of number when an application for a change of rider is approved or when other circumstances dictate that it is desirable to do so.

Applications for changes of machines and/or riders deemed, by the Clerk of the Course, to have as their object a change of number, will be refused.

15. RACE PROCEDURE

(a) Start Preliminaries

First Signal - 45 minutes before start.

Competitors take possession of machines in assembly area. Engines may be started for warm up period. Petrol and oil tanks may be topped up and adjustments made.

Second Signal - 30 minutes before start.

Third Signal – 15 minutes before start

Competitors marshalled to starting grid and lined up in order. Riders on the grid may at this stage make adjustments to the motorcycle or change tyres to suit the course conditions. Tyre warmers may be used on the grid, powered by a generator. Only one generator per machine may be used. The generator must be of the "hand carried" type and have a maximum output capacity of one kilowatt. The noise limit of the generator is 65 dB/A. No batteries or other electrical supplies are permitted on the grid except a self-contained starting device may be used. All adjustments and changes of tyres/wheels must be completed by the fourth signal.

Fourth Signal - 5 minutes before start.

Stand to, clear grid on the instructions of officials. Engines must be running. Exit gate from warm-up/assembly area to start line will close.

In exceptional circumstances, the start of any race may be officially delayed or a race may be reduced in number of laps or, if necessary, postponed until the following day or another designated day, abandoned or cancelled. Riders will be started at intervals of 10 seconds in pairs in each race or at such other intervals as the Club may determine; the regular intervals will be allowed for any non-starter and for no 13 (not allocated).

Riders will not start until the starting flag is dropped. Clutch or push starts will be permitted in all races. There will be an interval between classes in the Newcomers A/B, Classic 350/250cc, Lightweight/SuperTwin and Classic Superbike/Junior Post Classic races. The start order will be decided at the discretion of the Club taking previous experience into account. Any rider who starts before the starting flag is dropped, or who fails to start immediately the starting flag is dropped may be penalised.

A rider who is not in position to start within 10 seconds of the scheduled starting time may only start 10 seconds after the last competitor is scheduled to start. His/her starting time may be adjusted to coincide with the new starting position (normal interval times will be observed).

Only during the start procedure is a competitor permitted to stop on the course adjacent to his pit. At all other times a rider must use the pit access road and stop in front of his designated pit.

Fire retardant overalls must be worn by all mechanics/assistants at all times in the warm-up area and pit lane. Footwear worn by attendants must adequately protect the foot and not contain any studs, steel tips or anything likely to cause a spark.

(b) Pit Area and Pit Stops

(1) Pit Area

The Pit Area is a Licensed Petroleum Storage Area under the Isle of Man Dangerous Goods Act and as such the following conditions apply:

- There must be NO SMOKING or naked lights. Engines must be stopped whilst being refuelled. Any electrical equipment used or taken within 14ft of refuelling equipment must be either intrinsically safe or flame-proofed. This includes two-way radios, transistor radios, cellular telephones, cameras using electronic flash or motor drive and power tools. Spare batteries must be protected to prevent shorting across the terminals. Manx Radio earpieces are permitted. Please note that simply wrapping electrical equipment does not make it intrinsically safe and therefore no such equipment including electrically powered tools will be permitted in the pit area.
- Petrol cans used for filling and draining must be metal or BSI approved. Spare tanks in pits must be empty.
- Filling or refuelling of quick-fillers can be done only between one hour and 30 minutes before the scheduled start time of the race and after the fire service have arrived. Fire retardant overalls must be worn when filling or refueling tanks.
- When quick-fillers are being filled or drained, only those persons immediately involved and race officials are permitted in the pit area.
- Quick-fillers must be drained when the pit lane is closed towards the end of the race. Any fuel not removed will become the property of the Club. Fire retardant overalls must be worn when draining fuel tanks.
- Unused fuel or empty drums which have contained fuel must not be carried beneath the Grandstand but may be taken across the pit lane only at the start line end.

(2) Attendants

Each rider is permitted up to three attendants. Passes are non transferable.

Riders must make their own arrangements for their supplies, including fuel, and for their pit attendants.

Every rider is responsible for ensuring that his pit attendants comply with official instructions and regulations and particularly the following rules:-

- Only at his/her pit may the rider get assistance or replenishment. Giving instructions to riders by signal or by word of mouth will not be regarded as assistance within the meaning of this regulation.
- Only the rider's own attendants may assist him/her.
- Only when the machine is at or approaching the pit may the attendants get out of the pit to help the rider. They may not go beyond the safety line ie first line in front of pits.
- The attendants may make any adjustments, replacements or repairs and may replenish the motorcycle and hand out food or drink to the rider but must not use any parts, supplies or tools, other than spare wheels and tyres, except those previously lodged in his/her pit.
- One or two attendants may help the rider to restart.
- The use of purpose-made front wheel paddock stands designed to support unaided the front of the motorcycle during refuelling is permitted. The use of ramps or other means to elevate the front of motorcycles during refuelling is forbidden.
- Pit attendants are strictly forbidden to sit or stand on refuelling gantries.
- Pit Attendants must wear fire retardant overalls and suitable footwear at all times in the pit lane and warm up area.
- Footwear worn by attendants must adequately protect the foot and not contain any studs, steel tips or anything likely to cause a spark.
- Crossing of the pit lane will be permitted only at the top end of the pit lane and the crossing point will be closed during pit stops. Equipment may not be removed from pits until the end of the race except under official supervision.
- The use of signalling boards by riders' assistants is permitted but such boards must not exceed 24 ins x 24 ins in size, to which a handle projecting not more than 24 ins from the board may be attached.
- One attendant must remain in the pit at all times to receive messages.
- Remote starters will be allowed in the pit lane but must not be started until refueling is completed. All remote starters must be presented for examination and approved by the Chief Technical Official or his deputies during practice week.

(3) Pit Stops during races

With the exception of a rider having difficulty at the start of a race only, all pit stops will be made in the pit lane between the pits and the Grandstand.

A speed limit of 60kph is in force over the whole of the pit lane. The following penalties will be issued

for non compliance and will be a matter of fact with no right of protest or appeal.

61kph - 80kph - a time penalty of 30 seconds.

81kph - 100kph - a time penalty of 60 seconds

Over 100 kph - disqualification from the race.

The lifting of the front wheel of a motorcycle for the purpose of showmanship (whether in the pit lane or on the course and whether in practice or in a race) may be deemed to be dangerous riding and may result in disqualification.

(c) Finish of a race

Riders who have completed the designated number of laps for the race will be shown a chequered flag by an official standing at the finish line-. Riders - crossing the finish line without completing the designated number of laps - after the leading rider on the road has been shown the chequered flag may be - permitted to proceed on a further lap -Where in the opinion of the Clerk of the Course it is no longer possible to qualify for a replica, he -may order all competitors to stop as each crosses the finishing line, -.Riders not permitted to commence the final lap will be included in a partial classification established at the end of the penultimate lap of the race. Red lights will then be shown prior to the return road gate and a marshal showing a red flag will stand at the return road gate.

The rider must be in contact with his/her machine.

(d) Stopping a Race

A race will not be stopped prematurely unless the Clerk of the Course deems it necessary, but if so stopped before the leading competitor has completed half of the total race distance, the race will be declared abandoned. The finishing positions in an abandoned race will be ignored for the purpose of classification of the race result.

A race stopped after the leading competitor has completed half of the scheduled race distance will be deemed to have been completed. The Clerk of the Course reserves the right to postpone or abandon any or all of the races if he considers it necessary.

The Clerk of the Course may, notwithstanding the previous paragraphs, declare a result of any race based on such assessment as he thinks appropriate and, in doing so, may apply Section 10 of the ACU Standing Regulations for Road Racing to such extent (if any) as they think appropriate in the circumstances.

In the event of the Clerk of the Course stopping a race prematurely due to 'force majeure' circumstances, waved red flags will be displayed at various points on the Course on the instructions of the Clerk of the Course or his Deputy. Stationary yellow flags will be displayed at intermediate marshals' posts. In the event of the Clerk of the Course shortening (as opposed to stopping) a race, this decision may be given to all riders at various points on the course. In these circumstances the chequered flag will be displayed at the start/finish line.

16. PROTESTS AND APPEALS

Protest and appeals must be made in accordance with the National Sporting Code (Chapter 10) of the ACU and accompanied by a fee of £50.

17. WINNERS ENCLOSURE

At the conclusion of each race the first three finishers will be directed into the Winners Enclosure with their machines to conduct interviews with the host television and radio broadcasters. No other television or radio journalists will be permitted to operate in this area.

The Winners Enclosure will be separated into three distinct areas and certain passes will allow access to certain areas of the Enclosure. The centre of the enclosure will be the area the first three finishing machines will be parked. Only the competitors and their crew who have a pit team pass will be allowed in this area. No other pass holders will be permitted in this area. Outside of the main Enclosure will be two other areas. One will be clearly identified as a 'press pit' and will be for Gold and Silver Press Pass holders only. The remaining area will can be accessed by individuals with an Official Pass, Promoter Pass or Team Pass.

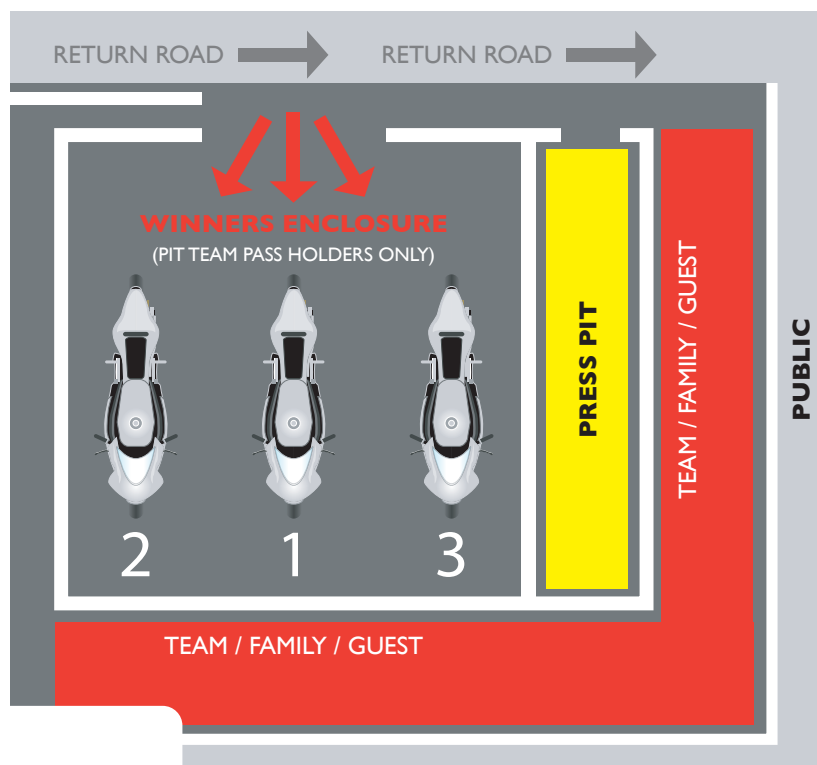

18. GARLANDING CEREMONY

Riders finishing 1st, 2nd and 3rd in each race will be required to take part in a short ceremony to be held in front of the Grandstand to acclaim and garland the winners. This ceremony will take place approximately 10 minutes after the third placed competitor has entered the winners' enclosure.

19. AWARDS

- THE MANX GRAND PRIX TROPHY donated by A B Crookall to the winner of the Senior race.
- THE JUNIOR MANX GRAND PRIX TROPHY donated in memory of Douglas Pirie to the winner of the Junior race.
- THE LIGHTWEIGHT MANX GRAND PRIX TROPHY donated by Motor Cycle to the winner of the SuperTwin race.
- THE ULTRA LIGHTWEIGHT MANX GRAND PRIX TROPHY donated in memory of Albert Moule to the winner of the Lightweight race.
- THE FRANCIS BEART TROPHY to the winner of the 500cc Classic Grand Prix race.
- THE TT MARSHALS' ASSOCIATION MEMORIAL CUP to the winner of the Formula Classic race.
- THE HAROLD ROWELL CUP to the winner of the 350cc Classic Grand Prix race.
- THE HARDING CUP to the winner of the 250cc Classic Grand Prix race.
- THE AITCHESON TROPHY to the winner of Class A of the Newcomers race.
- THE BRADDAN BRIDGE TROPHY to the winner of Class B of the Newcomers race.
- THE PHINIK TROPHY to the winner of the Classic Superbike race.
- THE EWAN HAMILTON TROPHY to the winner of the Junior Post Classic race.
- THE LORD WAKEFIELD CUP to the rider making the best overall performance in the opinion of the Club Committee in the Junior and Senior Manx Grand Prix races who is not a winner of either race
- THE LADY HILL ROSE BOWL to the rider who is a local resident making the most meritorious performance in the opinion of the Club Committee during the Senior Manx Grand Prix race.
- THE YORK TROPHY to the rider who is a local resident making the most meritorious performance in the opinion of the Club Committee during the Junior Manx Grand Prix race.
- THE RAY COWLES TROPHY to the rider in any Manx Grand Prix race (but excluding the Newcomers Race) who in the opinion of the Club Committee make the best performance on a 4 stroke machine of British manufacture
- THE GWEN CRELLIN COMMEMORATIVE TROPHY to the rider making the best overall performance in the opinion of the Club Committee in the 500cc/350cc/250cc Classic Grand Prix and Formula Classic races who is not a winner of either race
- THE DICK LINTON TROPHY to the rider who is a newcomer making the most meritorious performance in the opinion of the Club Committee during a Classic race.
- THE WALLACE CUP to the rider who is a local resident making the most meritorious performance in the opinion of the Club Committee during the Newcomers race.
- THE NAYLOR TROPHY the rider making the fastest race time on a 4 stroke twin cylinder machine having an engine and frame of British manufacture in the 500cc Classic Grand Prix race.
- THE LESLEY ANNE TROPHY to the female rider making the most meritorious performance in the opinion of the Club Committee.
- THE CROMIE McCANDLESS TROPHY to the rider who is an Irish resident making the most meritorious performance in the opinion of the Club Committee during the Manx Grand Prix races.

- THE NORRIE WHYTE TROPHY to the rider who is a Scottish resident making the most meritorious performance in the opinion of the Club Committee during the Manx Grand Prix races
- THE SEYMOUR TROPHY to the rider who is a National of a European country outside the British Isles making the most meritorious performance in the opinion of the Club Committee.
- THE MARTIN SMITH TROPHY to the rider who is a newcomer making the most meritorious performance in the opinion of the Club Committee during the Senior race.
- THE ALAN HAMPTON TROPHY to the rider who is a newcomer making the most meritorious performance in the opinion of the Club Committee during the Junior race.
- THE DAVE CORLETT TROPHY to the rider who is a newcomer making the most meritorious performance in the opinion of the Club Committee during the Super Twin race.
- THE PHILIP HAYHURST TROPHY to the rider who is a newcomer making the most meritorious performance in the opinion of the Club Committee during the Lightweight race.
- THE ENNETT TROPHY to the rider who is a newcomer making the most meritorious performance in the opinion of the Club Committee during the Classic Superbike/Junior Post Classic race.
- THE HOGG TROPHY to the rider who is a local resident making the fastest lap during the Manx Grand Prix.
- THE FRED WALMSLEY TROPHY to the rider of the highest placed single cylinder machine in the 500cc Classic Grand Prix race.
- THE GEOFF CANNELL TROPHY to the rider of the highest placed single cylinder machine in the 350cc Classic Grand Prix race.
- A MEDAL will be presented to the rider of the highest placed 125 cc machine in the Lightweight race
- A MEDAL will be presented to the rider of the highest placed 250 cc machine in the Junior race.
- A MEDAL will be presented to the rider of the highest placed 350 cc machine in the Junior Post Classic race.
- THE GJA BROWN CLUB TEAM TROPHY to the Club having the winning team in the Senior race.
- THE JW DAVIE CLUB TEAM TROPHY to the Club having the winning team in the Junior race.
- THE BILLS/HARDING CLUB TEAM TROPHY to the Club having the winning team in the Super Twin race.
- THE CASTLE HILL CUP to the Club having the winning team in the Lightweight race.
- THE GWEN CRELLIN TROPHY to the Club having the winning team in the 500cc Classic Grand Prix race.
- THE MANX TELECOM TROPHY to the Club having the winning team in the 350cc Classic Grand Prix race.
- THE BILL JACKSON SHIELD to the Club having the winning team in the 250cc Classic Grand Prix race.
- THE PADGETT TROPHY to the Club having the winning team in the Newcomers race.
- THE DICKIE DALE TROPHY to the rider making the fastest lap in the Senior race.
- THE G D HANSON TROPHY to the rider making the fastest lap in the Junior race.
- THE FREDDIE FRITH TROPHY to the rider making the fastest lap in the SuperTwin race.
- THE PAM CANNELL TROPHY to the rider making the fastest lap in the Lightweight race.
- THE MILNE SHIELD to the rider making the fastest lap in the 500cc Classic Grand Prix race.

- THE MYLCHREESTS CUP to the rider making the fastest lap in the Formula Classic race.
- THE MULARNEY TROPHY to the rider making the fastest lap in the 350cc Classic Grand Prix race.
- THE ARTHUR WHEELER TROPHY to the rider making the fastest lap in the 250cc Classic Grand Prix race
- THE PAUL BLADON TROPHY to the rider making the fastest lap in Classic Superbike race.
- THE GEORGE RIDGEON TROPHY to the rider making the fastest lap in the Junior Post Classic race.
- THE DUNCAN MUIR AND VAL CONATY TROPHY to the rider making the fastest lap in Class A of the Newcomers Race
- THE SEAN JACKSON AWARD to the rider making the fastest lap in Class B of the Newcomers race.

Please note - The above awards (except medals for the highest placed 125 cc in the Lightweight, 250 cc in the Junior races and 350cc in the Junior Post Classic) will remain in the custody of the Club after the presentation.

Replicas will be awarded to the 1st, 2nd & 3rd in all classes. Subsequent replicas will be awarded as follows:-

- 1) In the Newcomers, SuperTwin, Lightweight, Junior and Senior races to those riders who finish within 11/10^{ths} of the time taken by the respective winners or class winners;
- 2) In the 500cc/350cc/250cc Classic Grand Prix, Formula Classic, Classic Superbike and Junior Post Classic races to those riders who finish within 11/10^{ths} of the time taken by the first finisher who has not qualified to start in any TT solo race on the TT Mountain Course in the last two years or won a silver replica in any TT solo race on the TT Mountain Course in the last four years.

Each member of the winning team and the rider putting up the fastest lap in each of the races will receive an award. Medals will be presented to the winners of fastest lap trophies and other special awards. Finishers' medals will be awarded to riders who complete any race in compliance with the regulations but fail to qualify for any of the premier awards or replicas.

Club teams in each case shall consist of 3 members of a bona fide club affiliated to the ACU, SACU, MCUI or another national federation nominated by or on behalf of such club, on the form obtainable from the Race Office. The completed form should be lodged at the Race Office no later than 12 noon on the day preceding the race day with an entry fee of £15.00. Any application for changes must be lodged with the Race Office no later than 12 noon on the day preceding the race. In the case of a postponement of a race to another day, one or more riders may be substituted not later than 1700 hours on the day preceding the day to which the race is postponed. The winning club team will be decided on an aggregate basis. A club may enter more than one team but no rider shall be nominated for more than one team in any race. See ACU National Sporting Code as to eligibility for Club membership.

Please note: It is a condition of receiving any award that the winner/s of the award shall attend to receive the award unless excused by the Club for a good reason.

AWARD PRESENTATIONS: Details of the dates and venue will be included in Final Instructions.

20. TRANSPONDERS AND AUTOMATIC TIMING

All practices and races will be officially timed using a transponder based automatic timing system. It is the responsibility of each competitor to provide and properly fit a transponder; a fully charged AMB Tranx 260 or a directly compatible equivalent, at his/her own expense.

A separate transponder must be provided for each machine entered. The identification number(s) of the transponder(s) must be the same as the identification number(s) on the entry form for that machine and class. No additional Transponder/lap recorder device is permitted on the machine during practice or races. Any change to transponder identification must be approved by the Clerk of the Course at least one hour before the start of practice or race. See also Appendix I.

21. ON-BOARD CAMERAS AND GLOBAL POSITIONING SYSTEMS

Only riders authorised by the Clerk of the Course will be permitted to film from on-board cameras, or to carry GPS on their machines. Applications must be made on the official 'Application to the Clerk of the Course' form. Where such approval is granted, the installation of a camera or GPS and associated equipment is further subject to approval of the Chief Technical Officer:

22. MOBILE PHONES

The carrying and use of mobile phones in the Technical Inspections bays, the holding area and the pits is strictly forbidden unless the device is intrinsically safe.

23. PADDOCK

The paddock will be organised by the promoter and its appointed agent G4S (Isle of Man) Ltd.

The Paddock Manager for G4S (Isle of Man) Ltd will be Chris Heyes.

Tel 01624 649021

Fax 01624 649049

Mob 07624 495105

E-mail chris.heyes@im.g4s.com

Parking of all team vehicles will be under the control of the promoter and its appointed agent and all teams must respect the instructions received.

Space will be allocated by the promoter and its appointed agent based on the information submitted by competitors on their entry form. The paddock parking position will be made by the promoter and its appointed agent and the decision will be final. Teams and / or competitors will receive notification of their paddock parking position on arrival.

The Paddock will open at 9:00am on Monday 15th August 2011. Strictly no access before this date.

The Paddock will be segregated into various areas into which teams will be entitled to bring certain vehicles.

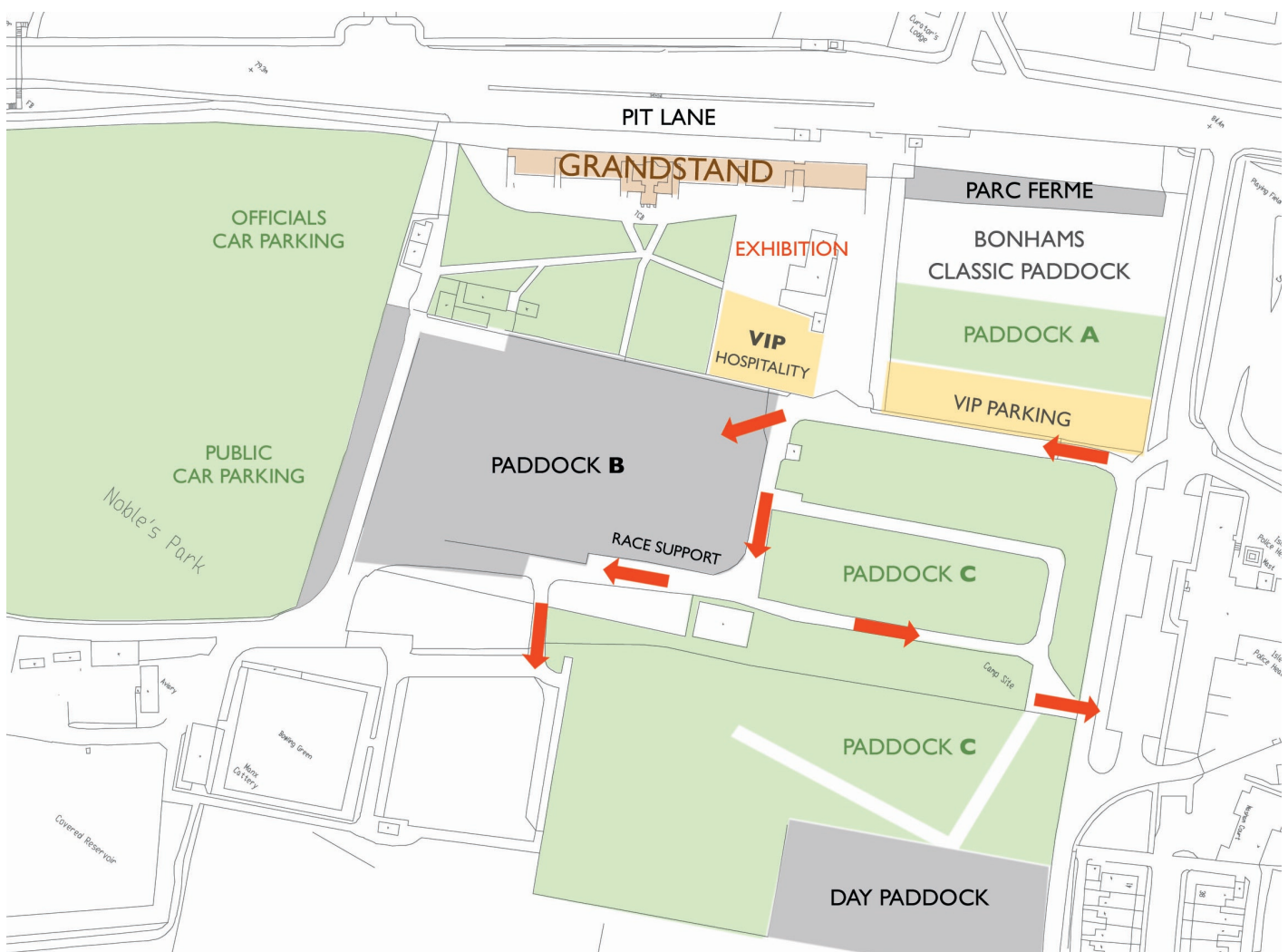

Retailing

Teams and competitors are not permitted to retail any goods or services from the paddock area during the MGP period including merchandise. Any team or competitor wishing to retail in the specific paddock trade area should contact Motorsport Promotions Ltd on 01624-667808.

Containers

Containers will not be allowed in the paddock.

Health and Safety

All competitors and their associated persons must at all times comply with all the health and safety requirements applicable in the paddock and displayed on the Race Office notice board.

Fire Extinguishers

All competitors / race support / trade personnel using the paddock will need to supply a fire extinguisher. The extinguisher must be visible at all times and have an in date certificate attached. Checks will be made during the event. All team members must be aware of its location and have knowledge in how it is operated.

Fire Points

Fire points are located within Paddocks A, B, and C and all team members must be familiar with their location. All Fire points are alarmed and extinguishers should not be removed unless needed in an emergency.

Welding / Welders

The use of welding equipment within the paddock area is strictly forbidden. Under no circumstance should teams or competitors bring welding equipment in to the paddock or associated areas. Any equipment found may be confiscated.

Generators

Generators must be placed in a safe working area. All cables used from generators or the electrical supply, must be covered by proprietary cable protector at all times. The use of generators should be kept to a minimum during night time hours.

Electrical Supply

Under no circumstance should anyone interfere with the electric supply from the power masters in the paddock. If an electric supply fails, please contact the Paddock Manager in the first instance. Teams and competitors are required to have all electrical equipment PAT tested prior to use.

Security

The paddock will be covered by security guards. There will be a foot patrol during daylight hours but no foot patrols between 1900hrs and 0700hrs.

Rubbish Removal

All competitors and team members are responsible for the removal of rubbish from parking and camping areas. Bins are provided for the disposal of bin bags located to the south of Paddock B.

Shower Block and Toilet areas

Showers and Toilet areas will be cleaned between the hours of 0700hrs to 2200hrs. All areas will be checked and cleaned every hour.

General Notice

A one way system will operate within the paddock. It has been designed for the smooth and safe transition of all vehicle movements. A 5 mph speed limit exists at all times. At no time should any vehicle block an entrance or exit.

Dogs will be permitted in the MGP grandstand area, including the paddock and Campsite, only if kept on a lead at all times.

24. PERSONNEL PASSES

There are different types of personnel passes depending on the activity of the pass holder:

Official Pass	(Red)
Promoter Pass	(Black)
Pit Team Pass	(Yellow)
Team Pass	(Blue)
VIP Guest Pass	(Green)
Guest Pass	(Orange)
Event Support	(White)

Official Pass (Red)

The Official Pass is issued to the personnel who operate in roles on behalf of the race organisers and will require access to all areas.

Promoter Pass (Black)

The Promoter Pass is issued to the personnel who operate in roles on behalf of the promoters and will have access to all areas except Pit Lane.

Pit Team Pass (Yellow)

The Pit Team Pass is issued to the personnel who work or do a professional activity during the event inside the restricted areas (Parc Ferme, Winners Enclosure, Start Line and including the Pit Lane). Under no circumstances should Pit Team Passes be allocated or distributed to guests and any such passes will be withdrawn. Fire retardant overalls must be worn by all personnel in Pit Lane and this rule will be strictly enforced.

Team Pass (Blue)

The Team Pass is issued to the personnel who work or carry out a professional activity during the event inside the restricted areas (Parc Ferme, Winners Enclosure Start Line) but not the Pit Lane. Under no circumstances should Team Passes be allocated or distributed to guests and any such passes will be withdrawn.

VIP Guest Pass (Green)

The VIP Guest Pass is issued by the promoters and provides access to the Official Isle of Man MGP Hospitality facility. Additional access to restricted areas (Parc Ferme, Start Line) will be granted by the promoter and such access will be marked on the pass. There will be four VIP Guest Passes, one for each race day, and will only be valid for the race day identified on the pass. This pass does not allow access to the Winners Enclosure or Pit Lane.

Guest Pass (Orange)

The Guest Pass is issued by the organisers and/or promoters and provides access to restricted areas Parc Ferme and Start Line. This pass does not allow access to the Winners Enclosure or Pit Lane.

Event Support Pass (White)

The Event Pass is issued to the personnel who work or carry out a professional activity during the event inside the restricted areas who are not race officials. This includes but is not restricted to personnel carrying out maintenance contractor work, cleaning and hospitality.

Pass General Rules

Teams and competitors are responsible for the integrity of the pass system within their team. Sanctions will be imposed on any team whose members abuse the pass system in any way including:

- Selling passes
- Production, sale or distribution of forged passes

Teams and competitors are also responsible for the behaviour of their guests. Guests should be advised that they are expected to respect the instructions of race officials.

By accepting the issue of passes for the 2011 Manx Grand Prix Races, the team and / or competitor are deemed to agree to abide by the pass conditions and to undertake the obligation to advise each person to whom a pass is issued of the pass conditions and to ensure the observance thereof.

Passes may only be used to gain access to the areas indicated on the face of it. Any person found within a restricted area without the appropriate pass may be removed from the venue immediately and / or have any pass held by them withdrawn.

Manx Grand Prix 2011 passes must not be removed from their official lanyards and must be worn around the neck of the person to whom it is issued so as to remain clearly visible at all times.

The organisers at all times reserves the right to refuse admission to the venue or access to a designated area to any person, notwithstanding that such person may have been issued with an appropriate pass.

Teams and competitors must keep accurate records of the numbers of passes that they issue to guests, this information must be available for audit by the organisers at an event. The organisers reserve the right to request further proof of identity in addition to a pass. 2011 Manx Grand Prix Races issued passes at all times remain the property of the organisers and may be issued, altered or withdrawn at any time at the absolute discretion of the organisers.

25. VEHICLE RECOVERY SERVICE

A recovery service will operate throughout the practices and races. Any machines collected will be returned to the Technical Inspections Bay. The Club does not accept any responsibility for any damage to any machine. Security is the responsibility of the competitor who must ensure that they or an attendant remains with the machine until collected.

26. ACCEPTANCE OF RECORDS

Entrants and riders must accept the official records of the Club which may be published as the Club thinks fit and also agree not to publish or allow to be published, on their behalf, any inaccurate, misleading or premature advertisement in connection with these races.

27. BREACH OF REGULATIONS

The Clerk of the Course is empowered to impose penalties of a reprimand and/or fine, or disqualification, for breach of these regulations where no other penalty is specified. Any rider not complying with instructions of an official of the meeting may be penalised.

28. INDEMNIFICATION OF THE CLUB

It is one of the conditions upon which entries are accepted for these races that the Club will not be responsible for any damage that may be done to any competing motorcycle or to its accessories during the meeting, either by fire, accident or otherwise, nor for the theft of the motorcycle or any of its accessories except as provided by Regulation 8.

29. JURISDICTION

Each entry, if accepted, will form a contract between the Club and the entrant/rider, which will be governed by and construed in all respects in accordance with Isle of Man Law. Each of the parties irrevocably submits to the jurisdiction of the Isle of Man Courts in respect of any legal action or proceedings arising out of the contract or the participation of the entrant/rider in the meeting.

30. PUBLICITY

Each competitor, as requested, must make themselves available free of any charge or expenses to the Promoter during the event for promotional purposes.

Riders finishing first, second and third in each race shall attend the podium ceremony.

In signing the 2011 Manx Grand Prix Entry Form each competitor and entrant agree that the promoter and the event sponsors may make use of his/her activities and successes in motorcycle sport for any advertising, publicity, public relations and merchandising purposes.

All riders may be required to carry an event and/or sponsors logo.

31. MERCHANDISING

The competitor and entrant will authorise the Promoter to use and reuse and licence the use of images and representations of the competitor and team motorcycles competing in the event (including the manufacturer's name and logo), and the name, images and representations of the competitor and team and team paraphernalia including (in so far as the same appears on the clothing worn by the competitor or on team paraphernalia or on the motorcycles participating in the event) the logo and decals of all sponsors of the competitor and/or team for the purpose of producing merchandise exploiting the reputation of the event.

The competitor and entrant acknowledge and agree that the Promoter and those authorised by it have the exclusive right to produce or authorise the production of interactive games of the event and games including individual elements of the event.

The competitor, entrant and/or team authorise the Promoter to use and licence others to use all event images and other material relating to the event in marketing and packaging material and commercial advertisements exploiting the event or merchandise of the event or any individual elements of the event.

The competitor and entrant shall assist the Promoter and those authorised by it with the promotion of the event and production and promotion of merchandise associated with the event.

32. MISCELLANEOUS

Riders, sponsors, manufacturers, entrants, and team personnel may not either individually or with any such participants or through any representative or agent, procure, solicit or arrange for any supplies, gratuities, products, merchandise, equipment or any other thing of value to be provided from any source whatsoever bearing or depicting the official Manx Grand Prix Festival logo(s) and/or any trademark and/or any copyright and/or image used or associated with the event without the prior written permission of the Promoter to do so.

All the broadcast, recording, terrestrial, cable, satellite, digital, video and rights in all other media (including but not limited to WAP or similar mobile communications platforms and/or devices, Internet, Interactive and/or other competitor accessed sources) to the Manx Grand Prix races are owned by the MMCC and are the subject of a licence granted by the MMCC to the promoter:

Any recording, broadcast, rebroadcast or reproduction without express permission of the Promoter is strictly prohibited. Competitors, entrants, sponsors or manufacturers currently registered in the event may, subject to the prior written permission of the Promoter and subject to any conditions that they may impose at their absolute discretion, be granted rights to use broadcast material for their own specific promotional use within the British Isles without fee or charge except any that may be levied for technical and or research purposes. Rights requested by sponsors, advertisers, or any other commercial use must be made in writing to the Promoter and will be subject to Licence, which may include a fee or charge.

33. USEFUL CONTACTS

Motorsports Team (Isle of Man Tourism)

Department of Economic Development
Upper Church Street
Douglas
Isle of Man, IM1 2PX
Tel: +44 (0) 1624 686802
Fax: +44 (0) 1624 686800
E-mail: iomtt@gov.im

Isle of Man Steam Packet Co Ltd

P O Box 5
Douglas
Isle of Man
Tel: +44 (0) 1624 661661
Fax: +44 (0) 1624 645608
E-mail: res@steam-packet.com

Motor Sport Risk Services

Lockton International
19 Spring Gardens
Manchester M2 1FB
Tel: +44 (0) 161 828 3300
Fax: +44 (0) 161 828 3335
www.locktonmotorsport.com
E-mail: dawn.luby@uk.lockton.com

Trading Standards Division (Isle of Man)

Office of Fair Trading
Lord St, Douglas
Isle of Man
Tel: + 44 (0) 1624 686520
Fax: + 44 (0) 1624 686504

IOM Vintage Motor Cycle Club

The Old Vicarage
Main Road
Kirk Michael
Isle of Man
Tel: +44 (0) 1624 878242
Email: tonyeast@manx.net

Isle of Man MGP Press Office

The Grandstand
Glencrutchery Road, Douglas
Isle of Man
Tel: +44 (0) 1624 644622
Fax: +44 (0) 1624 644642
E Mail : mgp@manx.net

ACU

ACU Road Race Department,
ACU House
Wood Street
Rugby, CV21 2YX
Tel: +44 (0) 1788 566400
Fax: +44 (0) 1788 573585
E-mail: rr@acu.org.uk

Transponders available from:

AMB it
Zuiderhoutlaan 4
2012 PJ Haarlem
The Netherlands
www.amb-it.com

APPENDIX I - APPLICABLE TO ALL MACHINES

1 TYRES

Owing to variations in weather conditions which can occur on the TT Course and in the interests of safety, only tyres having a moulded tread pattern will be permitted. No additional cutting of moulded tyres will be permitted. No slicks, cut or uncut, will be allowed. Metal valve caps (not extractor type) must be fitted. Valves must be of the short stub stem type.

2 OIL FILTERS

All spin-off oil filters must be jubilee clipped and wire locked.

3 WHEEL NUTS & SPINDLES

All wheel nuts and spindles must be wire locked. Where this is impractical, fork leg retaining/pinch bolts should be wired.

4 BRAKES

- i) Brake Lines: For machines fitted with two front disc brakes, the split of the front brake lines for both front calipers must be made at or above the lower fork.
- ii) Brake Calipers: Where the brake pad pin is retained by one fastener, a secondary fixing is required.

5 PREPARATION

Must be in accordance with the ACU Standing Regulations and these Supplementary Regulations. The Club reserves the right to refuse any entry or to forbid the use of any particular machine which the Club considers inappropriate for racing on the TT course, or otherwise not to be in the spirit of this event. All machines must be prepared to a high standard of cosmetic appearance. Untidy machines will not be permitted to start in any event.

6 COOLANTS

No liquid engine coolants, other than lubricating oil or water should be used. This is because oil based substances can be dangerous if spilt on the road.

7 BORE & STROKE

Bore and stroke must be clearly marked on the motorcycle.

8 EXHAUST SPRINGS

All exhaust springs including those to the cylinder head must also be held by wire to ensure that the springs remain on the machine in the event of spring failure.

9 OIL CONTAINMENT

In the interests of safety Standing Regulations will be enforced.

10 CHAIN GUARDS

A chain guard must be fitted in such a way as to cover the point where the chain runs onto the rear sprocket and irrespective of wherever the rear wheel is positioned to maintain correct chain tension. The guard must be made of substantial material and must be securely mounted to the swinging arm so that it cannot rotate and come into contact with the chain or sprocket.

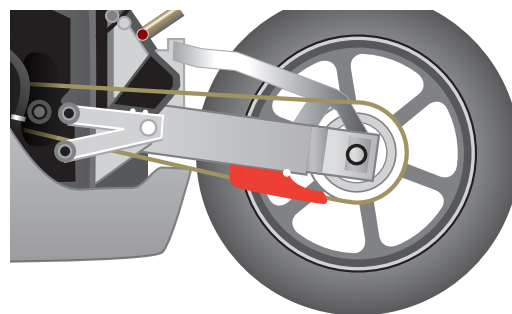

11 MONZA FILLER CAPS

All Monza filler caps must be fitted with an "R" clip or other device, to prevent unintentional opening of the cap. The device must be replaced after any pit stop.

II. TRANSPONDERS

- Ensure that the transponder holder is fitted securely, preferably using bolts and Nylock nuts (if tie-wraps are used at least two sufficiently strong tie wraps are needed to secure the holder)
- The transponder must be mounted **VERTICALLY** and **NOT** horizontally.
- The securing pin must be at the top
- Fit the transponder holder in a safe and secure position
- Mount the transponder so that it is preferably no more than 2 ft (60 cm) from the ground
- Mount the transponder so that it is away from heat generating bodies such as the exhaust
- Mount the transponder so that it has as clear a view of the ground as possible. Note – the transponder signal will not pass through metal or carbon fibre based plastics
- Push the 'R' clip right through as far as possible in order to prevent it being accidentally pushed out
- The transponder must be fitted whenever your machine is taken into the assembly area and whenever it is on the course, including timed and untimed practice sessions.
- The transponder must be charged and 'flashing' green and fitted to the machine when presented for Technical Inspections.

Disregarding any of the above guidelines may result in your time(s) not being recorded.

No time will be recorded at all if the transponder is not fitted or has not been charged.

PREFERRED POSITIONS:

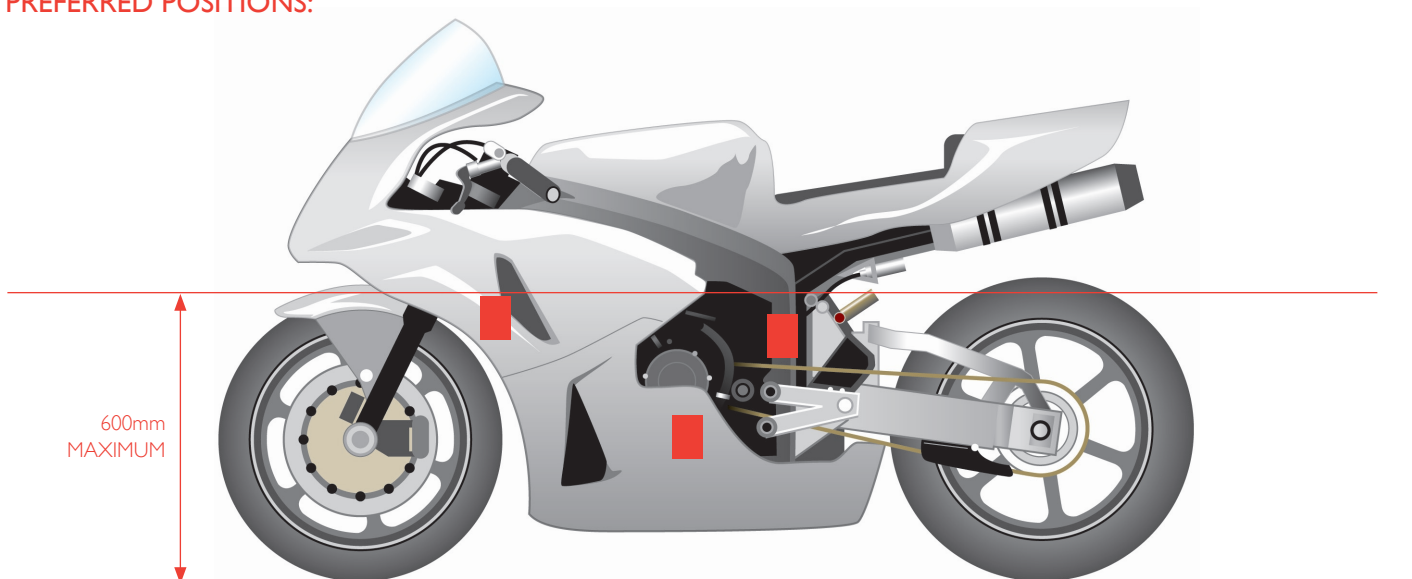

APPENDIX II - APPLICABLE TO CLASSIC & FORMULA CLASSIC MACHINES ONLY

In formulating the Classic Regulations, the Club has endeavoured to produce races for machines built using components available in the eligibility periods. When looking at entries consideration will be given to the period appearance of the machine as well as adherence to the letter of these regulations.

All components fitted must be of a type available and fitted to machines of the relevant classes within the relevant classic period, defined in paragraph 2 below. This includes all major components such as frame, forks, wheels etc. No modifications (other than those specifically authorised in these regulations) will be permitted unless used during the period. Where components are of later manufacture, they must exactly resemble the original period components. No machines with more than 2 cylinders will be permitted in the lightweight, junior or senior classes, except by special arrangement with the Club. The onus is on the rider or entrant to prove eligibility if required.

ELIGIBILITY SPECIFICATION

1 Oil Containment

Oil Containment is compulsory for all 4 stroke machines (ie faired and unfaired). The oil containment must be of rigid construction fastened securely to the machine and have a capacity of at least half of the total oil (and coolant) capacity in the event of an engine failure.

The oil containment for unfaired machines must be at least 50mm deep and at the front must extend upwards to at least 50mm below the base of the cylinder except in the case of horizontal cylinder machines (eg Aermacchi) which will be subject to the agreement of the Chief Technical Officer whose decision is final.

2 The MGP Classic races cater primarily for thoroughbred Grand Prix racing motorcycles constructed during:

- (i) the period 1 January 1945 to 31 December 1972 inclusive, for all 4 strokes up to 500cc;
- (ii) the period 1 January 1945 to 31 December 1974 inclusive for 4 stroke machines above 500cc; and
- (iii) the period 1 January 1945 to 31 December 1967 inclusive, for all 2 strokes (with the addition of Greeves Oulton and Bultaco TSS built before 31 December 1968) for the specific purpose of participation in competition during that era.

In addition, short circuit specials, of a type which can be shown to have a connection with the Isle of Man TT and MGP racing, will be considered on their merits. Such specials shall have a maximum of 2 cylinders and must have an appearance of a typical racing machine of the era. Formula Classic machines may be multi-cylinder.

Entries will not be accepted without a specification sheet for each machine entered and with photographs, with and without fairing, if applicable. Standard production machines will not be accepted. Riders who are in any doubt about eligible components or modifications are invited to contact the Chief Technical Officer via the Race Office for a ruling.

3 Seat, tank & fairing

Motorcycles must be presented in period condition. Seats, tanks and fairings (if fitted) must be of a pattern and type manufactured and used in the appropriate period, ie pre-1968 for 2 strokes and pre-1973 for 4 strokes (pre 1975 for 4 stroke and pre 1970 for 2 stroke Formula Classic machines). Fuel tanks are subject to the capacity of 24 litres (Reg 10h)

4 Wheels

Must be of a wire-spoked construction and of 18" or 19" diameter. A maximum rim width of WM3 for Classic classes ie up to 500cc machines, and a maximum rim width of WM4 for Formula Classic machines. Cast wheels will not be permitted, except for the Arter Matchless.

5 Tyres

No hand cut slicks or wet weather tyres will be permitted. Maximum tyre width, as stated on the manufacturer's specification sheet, shall be 4.50" for Classic machines.

Tyres must be fitted with inner tubes.

Approved rear tyres for 500 cc machines are Avon AM22, Dunlop KR 124, KR124A and KR108. Other makes of tyre are acceptable providing the maximum width does not exceed 4.50" (114mm).

6 Brakes

May be drum or disc for 4 strokes and Formula Classic 2 strokes. Only drum brakes may be used for 2 strokes. All disc brake components must be pre-1973 for 4 strokes (pre 1975 for Formula Classic). Floating discs, 4 piston callipers and adjustable master cylinders will not be permitted.

Discs must be solid and may be drilled only parallel to the wheel spindles. An unmodified out-of-period AP front brake master cylinder, part no CP3179-2 (plastic reservoir) is eligible.

For 2011 the AP Racing variable ratio front brake master cylinder parts no CP 3125-2 or CP 3125-4 may be used for the Classic Races.

Where a rider has a genuine reason for not being able to operate a conventional brake lever, a thumb operated brake lever will be permitted.

Due to space constraints, this may mean that an out of period master cylinder will be required. The use of such a device must be stated on the eligibility form and will be subject to prior approval by the Chief Technical Official.

7 Swinging arm, suspension & front forks

Must be of a pattern, type and material manufactured and used in the period.

8 Carburettors

Shall be of a type available in the era, ie pre-1973 for Classic 4 strokes and pre-1968 for Classic 2 strokes, pre 1975 for Formula Classic 4 strokes and pre 1970 for Formula Classic 2 strokes.

Amal Mk II concentric carburettors, including smooth bore derivatives may be used. Pumper carburettors of any type are not permitted even if the pumper is blocked off or disabled. Power jet carburettors are not permitted.

Fuel injection is not permitted. Keihin carburettors must be of "Tickler" type - the later mechanically operated choke type is not approved.

9 Engine and gearbox

May be modified internally and/or fitted with components of modern manufacture. All engine and gearbox casings must be unmodified externally, except modifications carried out in the period, to permit the fitment of belt primary drives, or to permit the repositioning of controls. All primary drives (belt and chain) must be totally concealed from view.

Multi-valve heads are not permitted, unless available and used in the era. Non-period components, eg engine castings, oil filter castings, cylinder barrels and expansion chambers will not be permitted. External oil pumps are not permitted.

10 Clutch

Slipper clutches are not permitted. Dry clutches are not permitted unless originally fitted in the period.

11 Electric starters

Machines are not permitted to have an electric starter fitted.

12 Replica frames

Will be permitted provided they are dimensionally accurate copies of known period chassis. For chassis without known pedigree, entries must be supported by documentary evidence proving eligibility.

13 Sound

For classic and Formula Classic machines, the ACU has granted a waiver of the sound level permitted under Standing Regulations.

14 Exhausts

Must comply with ACU Standing Regulations

SUMMARY OF TIMES

1. SIGNING-ON - PRE PRACTICE

Friday 19 August	1300 - 1600 (All riders including Newcomers)
Saturday 20 August	0900 – 0930 (Newcomers only) followed by course instruction) 0930 – 1100 (All other riders)

2. BRIEFINGS

Friday 19 August	1400	1500	1630
Saturday 20 August	1115 (All riders except Newcomers)	1200 (Newcomers Only)	
Monday 22 August	1600		

All Newcomers (any class) must arrive, sign on, take the Newcomers Course Instruction at 0930 hrs and attend the Newcomers (any class) briefing at 1200 hrs on Saturday 20 August or they may be excluded.

TECHNICAL BRIEFINGS

On Saturday 20 August: All riders except Classic 1315 Classic riders 1400

NEWCOMERS' PRE-RACE BRIEFING

At 1100 on Sat 27 August in the Pit Lane area if dry and Technical Inspections Bay if wet. This is compulsory.

3. NEWCOMERS' COURSE INSTRUCTION

Departs at 0930 on Saturday 20 August immediately after the Newcomer signing on session. This is compulsory and failure to attend may result in disqualification.

4. TECHNICAL INSPECTIONS (Pre Practice)

Saturday 20 Aug	1500-1600 1530-1910 1630-2010	Newcomers incl Classic, C/Superbike & Jun P/Classic Newcomers Senior; Junior; SuperTwin (No Newcomers) Classic, C/Superbike, Jun P/Classic, Lightweight
Monday 22 Aug	1600-1900 1715-2000	Senior; Junior; SuperTwin (No Newcomers) Classic, C/Superbike, Jun P/Classic, Lightweight, New A & B
Tuesday 23 Aug	1600-1900 1715-2000	Classic, C/Superbike, Jun P/Classic, Lightweight, New B Senior; Junior; SuperTwin, New A
Wednesday 24 Aug	1600-1900 1715-2000	Senior; Junior; SuperTwin, New A Classic, C/Superbike, Jun P/Classic, Lightweight, New B
Thursday 25 Aug	1600-1900 1715-2000	Senior; Junior; SuperTwin, Newcomers A Classic, C/Superbike, Jun P/Classic, Lightweight, New B
Friday 26 Aug	1600-1900 1715-2000	Classic, C/Superbike, Jun P/Classic, Lightweight, New B Senior; Junior; SuperTwin, New A
Saturday 27 Aug*	1600-1900 1715-2000	Senior; Junior; SuperTwin, (No Newcomers) Classic, C/Superbike, Jun P/Classic, Lightweight (No Newcomers A & B)
Monday 29 Aug*	1000-1130	All Classes except Newcomers A & B, Junior; 350/250cc Classic
Wed 31 Aug*	1000-1130	Senior; Classic Superbike, Jun Post Classic

* subject to race delays

4. TECHNICAL INSPECTIONS (Pre Race)

Newcomers (Sat 27 August)

All Nos 1500-1630

All Other Classes

Nos	6l upwards	0800-0830
Nos	3l – 60	0830-0900
Nos	1 - 30	0900-0930

Any application for extension must be made during the times stated above

5. RACE TIMES

- 45 minutes before the start. Riders take possession of machines in holding area
- 15 minutes before the start. Riders marshalled to starting grid.
- 5 minutes before the start. Stand to. Clear grid.

Saturday 27 August

1730 Race 1 The NEWCOMERS RACE

Monday 29 August

1015 Race 2 The 350cc/250cc CLASSIC GRAND PRIX RACE
1315 Race 3 The JUNIOR MANX GRAND PRIX RACE

Wednesday 31 August

1015 Race 4 The 500cc CLASSIC GRAND PRIX/FORMULA CLASSIC RACE
1315 Race 5 The SUPERTWIN / LIGHTWEIGHT MANX GRAND PRIX

Friday 2 September

1015 Race 6 The SENIOR MANX GRAND PRIX
1315 Race 7 The CLASSIC SUPERBIKE/JUNIOR POST CLASSIC RACE

